

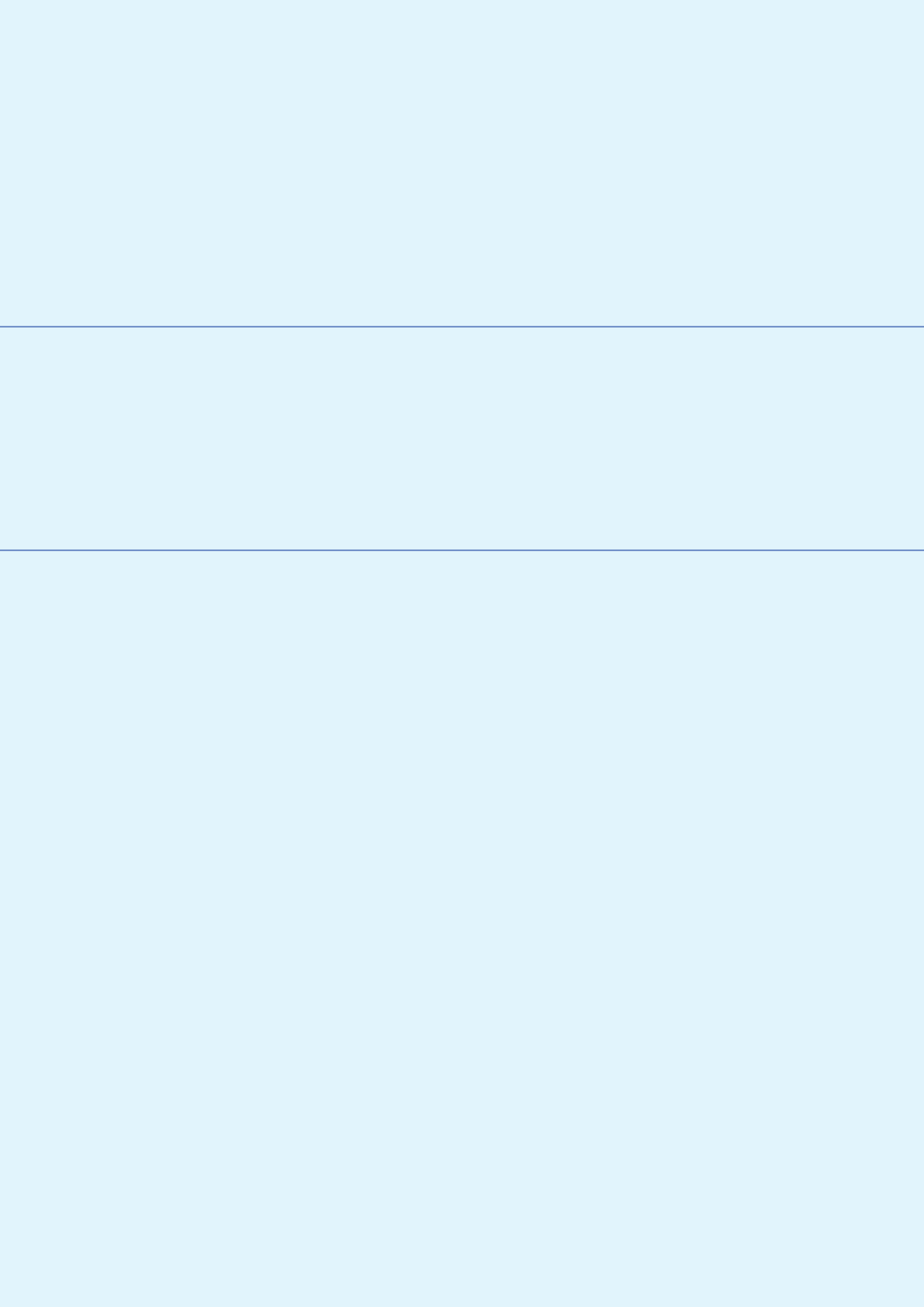

*Leader in
Aluminium
Industry*

impol
Aluminium Industry







*Enriched by Experience -
Prepared for Future
Challenges.*





2022

Creation of InfiniAl,
Impol's low-carbon aluminum brand.

2018

Impol develops a product
finalization program.

2016

Impol buys rolling company Impol-
TLM d.o.o. in Croatia.

2004

Impol buys a 70% share
in Impol Seval a.d. in Serbia.

1998

Impol becomes a privately owned
company.

1991

Slovenia declares independence.
Company focuses on export (80%).

1950

Transformation from copper
to aluminium.

1825

Founding of a company producing
forged copper products.

170
allo

sustain

A Large Player in the World of Aluminium

At Impol, we transform aluminium into cutting-edge solutions that drive our customers' success.

Our broad portfolio of flat rolled and extruded products makes us a one-stop source for all aluminium needs, ensuring convenience, consistency, and reliability.

With our own foundries, we control the entire process – from raw material to the final product – enabling limitless opportunities to develop advanced aluminium alloys with superior mechanical properties.

Today, we offer more than 170 alloy types, and our range keeps growing.

Many of these alloys are created hand-in-hand with our customers, reflecting our role not just as a supplier, but as a trusted partner in innovation and growth.

Our state-of-the-art laboratories safeguard uncompromising quality, giving you the confidence that every Impol product will perform at the highest level.

Our unwavering commitment to sustainability – and our constant drive to shape the future – has enabled us to successfully overcome challenges and thrive. Today, Impol is a trusted partner to customers, suppliers, employees, and investors worldwide.

No.1

We are proud of our strong track record in product development. In Europe, we lead the market in rods for forging and hold the largest share in piston rods. At the same time, we are actively expanding our presence in rolled products, reinforcing our position as a stable and dependable supplier.

We believe in building long-term partnerships based on trust, collaboration, and the continuous exchange of knowledge – ensuring shared growth and success.

ys

nability

PRODUCTS OF THE FUTURE

The Impol Group produces high-quality semi-finished aluminium products, sought after worldwide for their superior properties, adaptability to customer requirements, and alignment with modern market trends.

GROWTH & TRADITION

Since the early 1990s, the Impol Group has enjoyed steady growth. Its recent 200th anniversary is a clear sign of the company's stability.

STRATEGIC POSITIONING

The company maintains a stable business environment through diversification across geographical markets, operations in several industries, a broad product range, and a well-chosen business model. This makes Impol a reliable and trusted business partner.

INVESTMENTS
OF OVER
400
MILLION EUROS IN THE LAST
TEN YEARS



130
% PRODUCTION GROWTH
IN THE PAST TEN YEARS



PRODUCTION CAPACITIES:
MORE THAN
250,000
TONNES OF PRODUCTS



MORE THAN
170
ALLOYS



MORE THAN
2400
EMPLOYEES



MORE THAN
100,000
DIFFERENT PRODUCTS



IMPOL 2000 D.D.		
IMPOL D.O.O.		
ALUMINIUM DEPARTMENT		
FOUNDRY DIVISION	ROLLING DIVISION	EXTRUSION AND DRAWING DIVISION
IMPOL LLT D.O.O.	IMPOL FT D.O.O.	IMPOL PCP D.O.O.
IMPOL SEVAL A.D.		STAMPAL SB D.O.O.
IMPOL-TLM D.O.O.		IMPOL FINAL D.O.O.
RONDAL D.O.O.		



	SERVICE AND COMMERCE	SUPPORT SERVICES	REAL ESTATE	INVESTMENTS IN RELATED COMPANIES
	IMPOL ALUMINUM CORP	IMPOL R IN R D.O.O.	ŠTATENBERG D.O.O.	SIMFIN D.O.O.
	UNIDEL D.O.O.	IMPOL INFRASTRUKTURA D.O.O.	IMPOL-MONTAL D.O.O.	
	IMPOL SERVIS D.O.O.	KADRING D.O.O.	IMPOL STANOVANJA D.O.O.	
	IMPOL HUNGARY KFT	ALCAD D.O.O.		



Creating Value For Our Customers

PARTNERING UP FOR SUCCESS

Certified quality and full traceability are only part of what drives the Impol Group's success. Equally important is our dedication to building strong partnerships across the entire supply chain – from primary aluminium producers, to our own foundry where secondary aluminium is recycled, to rolled or extruded semi-finished products delivered to customers, and finally to end products serving a wide range of industries.

By working closely with suppliers and customers, we strive to identify shared opportunities for innovation, develop new technological solutions, and create the alloys and products that the aluminium market both needs and expects. With a team of highly qualified specialists, we are not only a supplier but also a trusted advisor – ready to actively contribute our expertise to every stage of this development process.

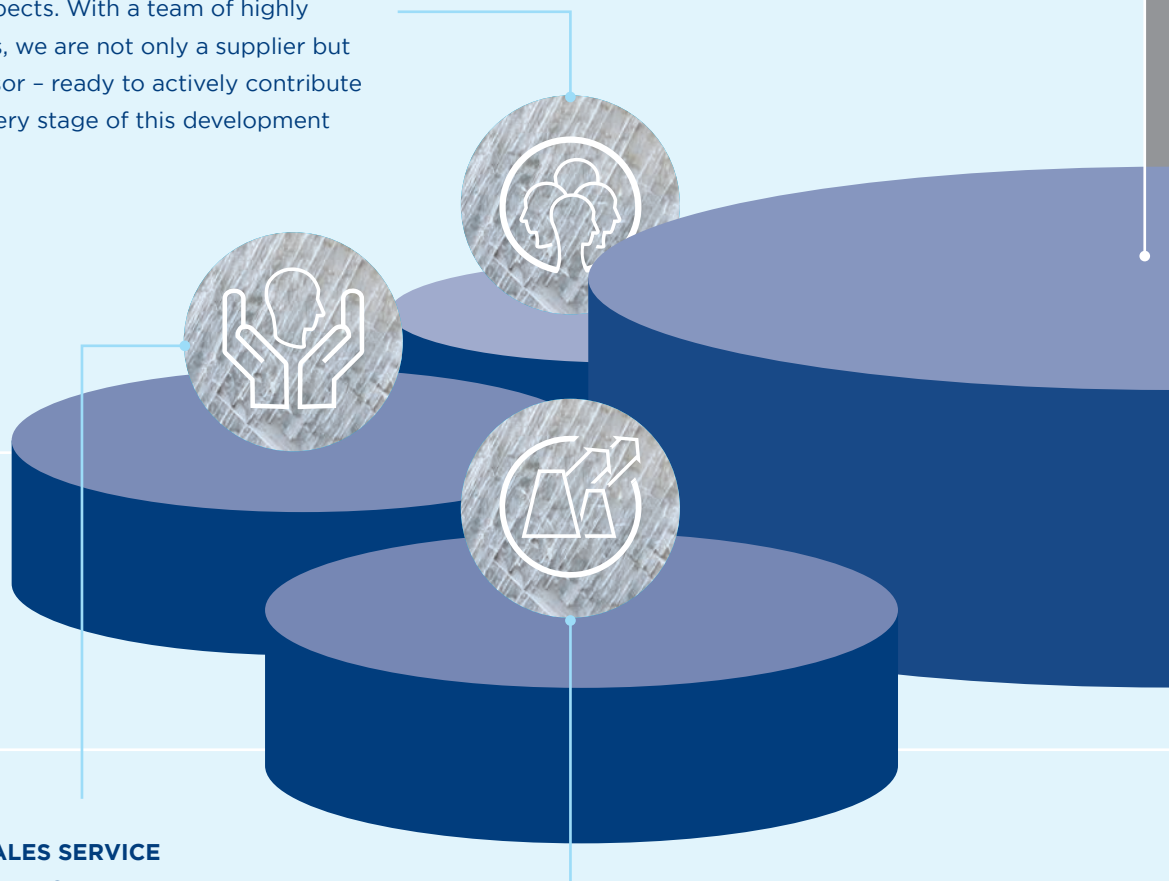

SUPERB AFTER-SALES SERVICE AND CUSTOMER SUPPORT

We aim to build lasting customer relationships, which is why we place great emphasis on well-structured after-sales service. Being available for advice and support throughout our customers' ongoing processes is a top priority. Our strong team of technologists and highly experienced specialists is ready to assist in the development of new alloys and products. Customers value Impol as a reliable partner whose expertise ensures that every contract is fulfilled on time and to the highest standard.

FLEXIBLE ORGANIZATION

The Impol Group readily adapts to the changing needs of its business partners and the market, providing practical, effective solutions. We achieve this through the continuous upgrading of our technological processes, optimising production and maximising material efficiency. Our extensive range of machinery enables a highly versatile production process, serving as both a safeguard and a guarantee that every order will be delivered on time.

development

PROVIDING A WIDE RANGE AND DEVELOPMENT OF ALLOYS

Twenty years ago, our foundry produced around 50 different alloys. Today, that number has grown to more than 170. This diversity sets Impol apart as one of the few providers able to offer such an extensive range, along with dedicated research and development support for introducing new alloys. Several of our alloys are protected by patents.

COMPREHENSIVE ALUMINIUM PROGRAMME

Impol brings the production of extruded and rolled aluminium semi-finished products under one roof, enabling us to compete comprehensively in the aluminium market through our in-house foundry capacities and advanced laboratories. We also operate our own small-scale forging facilities, producing a distinctive range of forgings. Slugs form a dedicated production segment, complete with its own marketing focus.

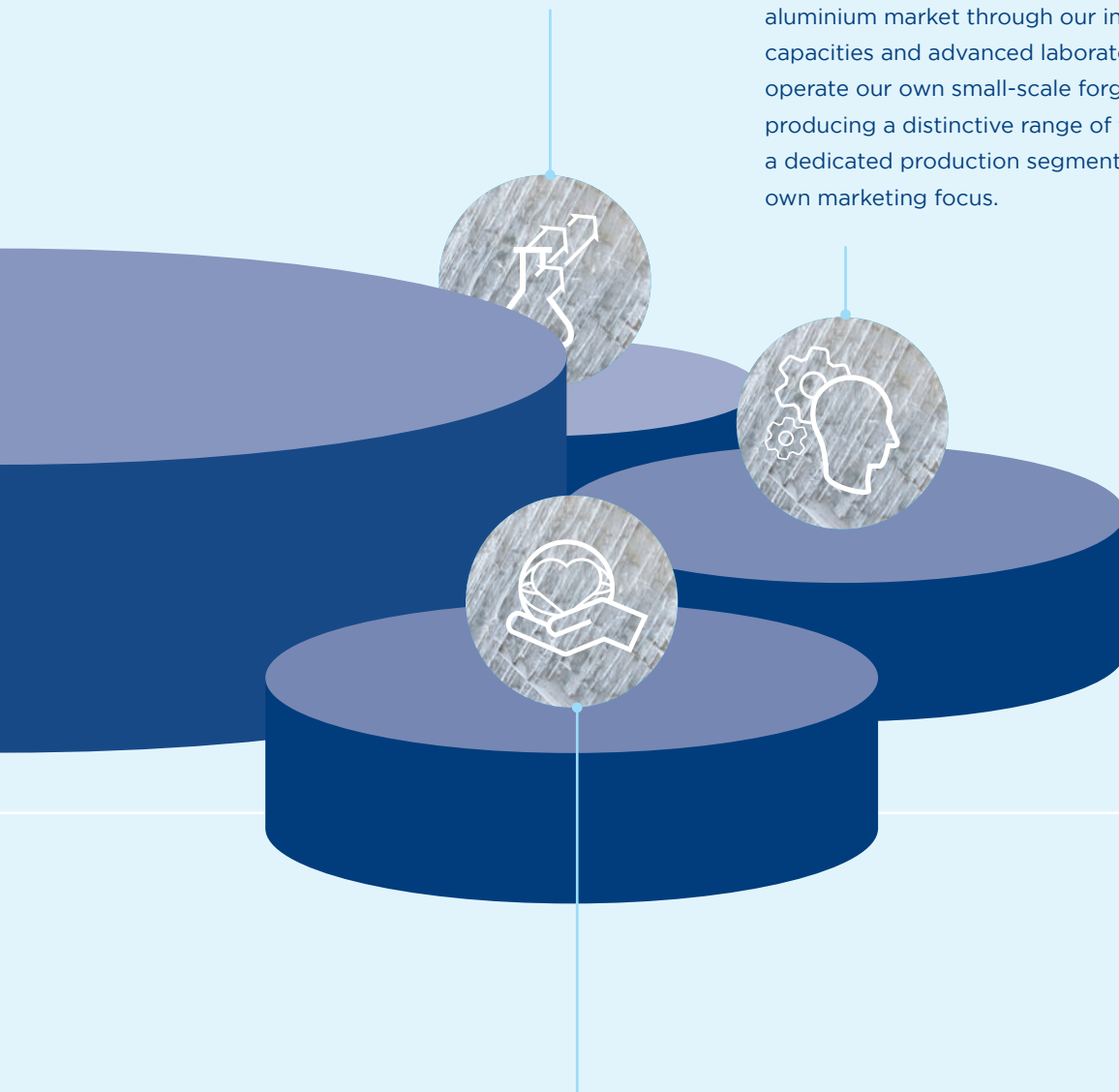

YOUR GATEWAY TO EUROPEAN ALUMINIUM

From our strategically placed facilities in Slovenia, Serbia, and Croatia, we are ideally positioned to serve global markets quickly and cost-effectively. Our central location allows us to deliver with speed, flexibility, and competitive transport costs – giving our customers around the world a reliable supply partner they can count on.

flexibility



SHEETS



**PRINTED
COILS &
SHEETS**

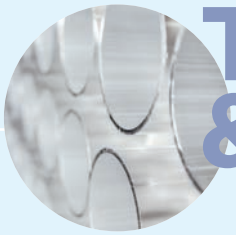

**TUBES
& PIPES**



**TREAD
PLATES**

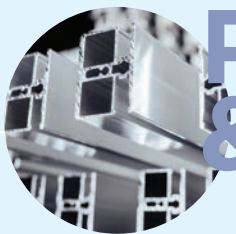

**PROFILES
& SECTIONS**



**RODS
& BARS**

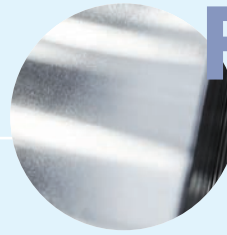

FOILS

One-Stop-Shop

Our endless flexibility and adaptability drive high customer satisfaction across all markets. Offering a wide range of top-quality products in one place, we make it easy for customers to get exactly what they need. With production tailored to specific size and volume requirements, we have become an indispensable partner in the aluminium industry.

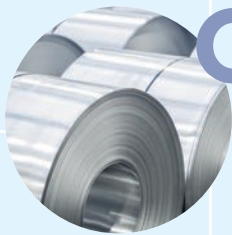

COILS

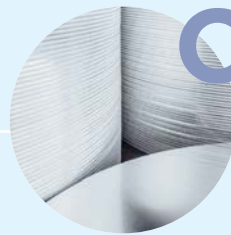

CIRCLES





FORGINGS



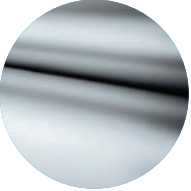
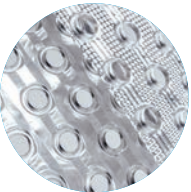
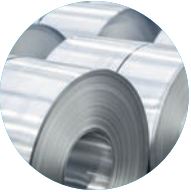
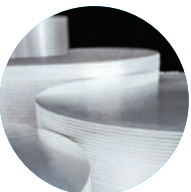

SEMI-FINISHED CAST PRODUCTS

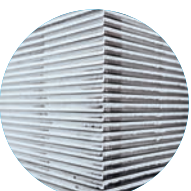
ROLLED PRODUCTS



PRODUCTS	MARKETS	USAGE	FEATURES
FOILS 	<ul style="list-style-type: none"> – packaging – transport – construction 	<ul style="list-style-type: none"> – packaging of food & pharma – products – enology – cables – insulation – household use 	<p>Excellent barrier to light, gases and moisture, lightweight, high mechanical properties, formability and strength.</p>
FIN-STOCK 	<ul style="list-style-type: none"> – transport – construction 	<ul style="list-style-type: none"> – heat exchangers 	<p>High thermal conductivity, good formability, corrosion resistance, energy efficiency.</p>
COILS 	<ul style="list-style-type: none"> – engineering – construction 	<ul style="list-style-type: none"> – engineering – transport – cladding – insulation... 	<p>Various alloys, tempers and dimensions according to customer requests, further operations of slitting and embossing.</p>
CIRCLES 	<ul style="list-style-type: none"> – consumer goods – industry 	<ul style="list-style-type: none"> – cookware – lightning – gas containers 	<p>Excellent deep drawing and spinning quality, wide selection of sizes and shapes, clean and reflecting surface.</p>
THREAD PLATES 	<ul style="list-style-type: none"> – transport – engineering – construction 	<ul style="list-style-type: none"> – engineering – building – wagon – ship and vehicle – bridges – ramps – floors – decorative interiors 	<p>Excellent grip, shiny surface, good corrosion resistance, selection of different patterns.</p>
SHEETS 	<ul style="list-style-type: none"> – engineering – construction 	<ul style="list-style-type: none"> – engineering – transport – cladding – insulation... 	<p>Various alloys, tempers and dimensions according to customer requests, protection with paper and special plastic.</p>

<p>PAINTED COILS & SHEETS</p> 	<ul style="list-style-type: none"> – transport – construction – consumer goods 	<ul style="list-style-type: none"> – roofing – facades – building accessories – panels – suspended ceilings – sun protection elements 	<p>Wide selection of colors, adaptation to customer needs, corrosion resistance, flatness.</p>
--	---	---	--

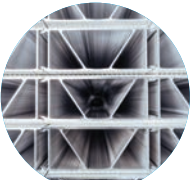
EXTRUDED AND DRAWN PRODUCTS

PRODUCTS	MARKETS	USAGE	FEATURES
<p>EXTRUDED BARS</p> 	<ul style="list-style-type: none"> – automotive – transport – construction – electro industry 	<ul style="list-style-type: none"> – safety parts in cars – parts for air-conditioning applicatios 	<p>Customer specific extrusions, development of special wrought alloys for use in different applications.</p>
<p>DRAWN BARS</p> 	<ul style="list-style-type: none"> – automotive – transport – construction – electro industry 	<ul style="list-style-type: none"> – bolts – fixings – connectors – pressure vessels 	<p>Innovative alloy development, technical consulting in material and process technology.</p>
<p>TUBES AND PIPES</p> 	<ul style="list-style-type: none"> – automotive – transport – construction – electro industry 	<ul style="list-style-type: none"> – drive-systems – cooling-systems – construction – trusses 	<p>Customer specific extrusions, innovative alloy development, after treatment of the products.</p>
<p>PROFILES AND CUSTOM MADE PROFILES</p> 	<ul style="list-style-type: none"> – automotive – transport – construction – consumer goods – electro industry 	<ul style="list-style-type: none"> – construction – windows – solar systems – instrument casings – furniture 	<p>Customer specific extrusions, innovative alloy development after treatment of the profile, use of special wrought alloys.</p>

NICHE PROGRAMMES

PRODUCTS	MARKETS	USAGE	FEATURES
<p>FORGED & MACHINED ALUMINIUM PARTS</p> 	<ul style="list-style-type: none"> – automotive – motorcycling – cycling 	<ul style="list-style-type: none"> – drive-systems – cooling-systems – compressors – parts of cycles – sports requisite – engines – suspensions – transmissions – braking systems 	<p>The average weight of forgings varies from 0.05 to 5 kg.</p> <p>A wide range of aluminium alloys is used for forging - from 2000 to 7075.</p> <p>Dimensional precision and good mechanical properties.</p>
<p>SLUGS</p> 	<ul style="list-style-type: none"> – food industry – cosmetics industry – pharmaceutical industry – electrical industry – automotive industry 	<ul style="list-style-type: none"> – tubes – cans – technical parts in automotive & other industries 	<p>Various alloys (EN AW-1070, -1050, -3102 & -3207).</p> <p>Hot- and cold-rolled, various thicknesses and coiled.</p>

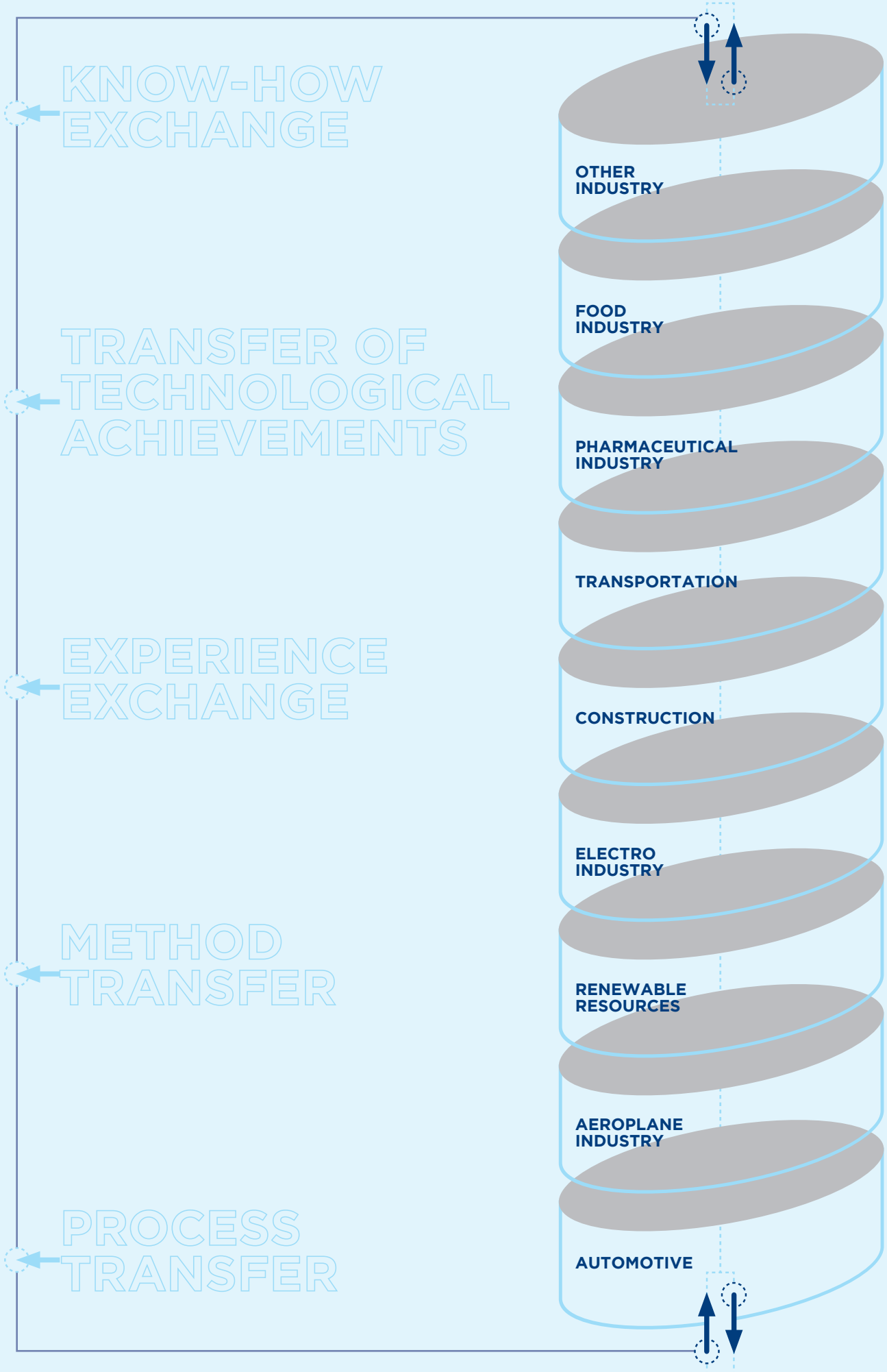

KNOW-HOW EXCHANGE

TRANSFER OF TECHNOLOGICAL ACHIEVEMENTS

EXPERIENCE EXCHANGE

METHOD TRANSFER

PROCESS TRANSFER

OTHER INDUSTRY

FOOD INDUSTRY

PHARMACEUTICAL INDUSTRY

TRANSPORTATION

CONSTRUCTION

ELECTRO INDUSTRY

RENEWABLE RESOURCES

AEROPLANE INDUSTRY

AUTOMOTIVE





*Our Production
can be customized
to meet Customers'
specific Needs.*





CONSUMPTION



PRODUCTION OF FINISHED PRODUCTS

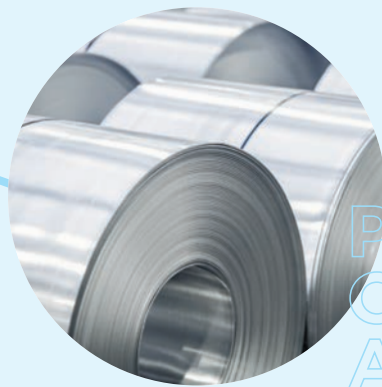

PRODUCTION OF SEMI-FINISHED ALUMINIUM PRODUCTS



PRIMARY ALUMINIUM PRODUCTION



RECYCLING

Green Aluminium. Our Opportunity.

Aluminium offers outstanding possibilities for reuse and recycling, as it can be melted down and reused with minimal loss. Recycled aluminium retains its excellent properties and requires only 5% of the energy needed to produce the same amount from primary sources.

Thanks to its unique characteristics, aluminium also serves as a high-performance energy accumulator with an endless lifespan. **Remarkably, nearly 75% of all aluminium ever produced is still in use today.**

ALUMINIUM AND THE CIRCULAR ECONOMY, I.E. THE FEEDBACK LOOP

Impol keeps pace with global trends by increasing its share of processed secondary aluminium year after year. Recent investments in our foundry have expanded production capacities and introduced advanced technology, enabling us to melt scrap aluminium into products of superior quality.

We have developed a comprehensive sourcing system that draws aluminium from multiple channels - in-house production scrap, industrial scrap from customers and suppliers, and collected post-consumer scrap - ensuring a sustainable and efficient closed-loop process.

BAUXITE
ORE MINES

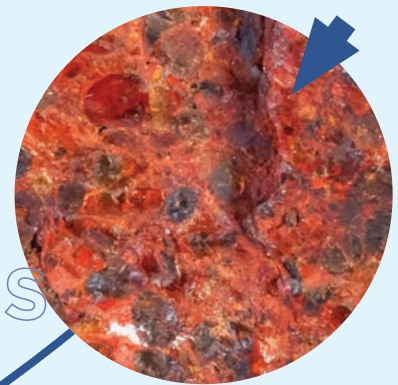

ALUMINA
PRODUCTION



ISO 9000

BVQI SINCE 1992

ISO 14001

BVQI SINCE 2000

ISO 45001

BVQI SINCE 2000

IATF 16949

BVQI SINCE 2004

EN 9100

BVQI SINCE 2018

Uncompromised Quality

The quality of our products is subject to certification and testing in the state-of-the-art, independent labs of the Impol Group, i.e. the labs for metallurgical, metallographic and chemical testing.

The metallurgical testing lab conducts mechanical tests, hardness tests and tests of the material's deep-drawing properties. Keeping up with the latest findings in the field of testing, we are consistent in implementing the most recent standards in our testing methods.

The metallographic testing lab is concerned with analysing the material's history and characterising the segments of its microstructure. Metallographic analysis is conducted via optic microscopy. Electron microscopy featuring an EDS detector is used to produce more reliable results in identifying the type of material and individual fragments.

The chemical testing lab carries out spectroscopic analyses of the chemical composition of aluminium alloys, analytical chemistry and waste water analysis.

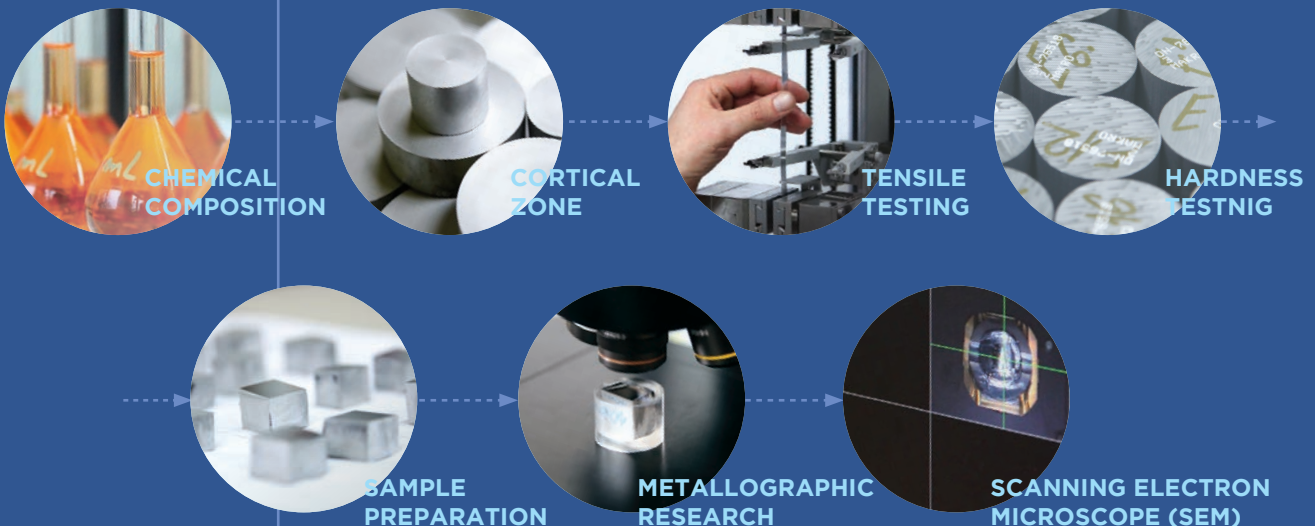

Seven Pillars of Social Responsibility



SUSTAINABLE PRODUCTS

Aluminium is the metal of today – and even more so, the metal of the future – as recognised by leading manufacturers across various industries. Lighter than steel, it offers outstanding processing characteristics and superior force absorption. In the automotive sector, using aluminium can reduce vehicle weight by up to 40%, leading to lower fuel consumption and reduced emissions.

The construction industry, which accounts for a quarter of global aluminium consumption, values its positive impact on energy efficiency. As a packaging material, aluminium reduces the weight of packaged goods while providing excellent protection. In fact, aluminium saves more energy resources than it consumes over its lifecycle. It is also an essential element in modern architecture and design, aligning perfectly with contemporary aesthetic and sustainability standards.



AN INNOVATIVE BUSINESS MODEL – MOVING TOWARD A CIRCULAR ECONOMY

In today's world, defined by both hyperproduction and limited resources, the importance of environmental protection and preserving natural resources has never been more evident. As a result, many companies are embracing circular business models that enable the reuse of valuable materials. Aluminium – and particularly secondary aluminium – embodies this principle, as it can be recycled infinitely while retaining its original properties.



RECYCLING

Recycled aluminium retains all of its original properties. With its high intrinsic value, it makes strong economic sense to return aluminium into the cycle of extraction, use, and recycling. Unlike many other materials, aluminium can be re-melted and reused endlessly without compromising quality. Proper waste separation is key to successful recycling, which is why the Impol Group invests heavily in training its employees and raising public awareness about the importance of recycling to protect our environment.



RESPONSIBILITY TO NATURE

Reducing pollution is one of the Impol Group's key business objectives, supported by an annual investment programme dedicated to environmental protection. Over the past three years, we have invested more than two million euros in this area, with one of the largest projects being the installation of a solar power plant. In addition, we fund a variety of initiatives aimed at improving the quality of life in our local community.



RESPONSIBILITY TO OUR LOCAL COMMUNITY

The Impol Group is one of Slovenia's largest employers and a multiple recipient of regional best-employer awards, playing a significant role in the quality of life of the local community. Our commitment to the local environment is reflected in numerous activities – from sponsoring associations and events, to supporting municipal development and enhancing local educational programmes. In recent years, Impol has repeatedly been recognised as a top employer in the region, underscoring our dedication to both our employees and the broader community.



RESPONSIBILITY TO OUR EMPLOYEES

Our responsibility to employees is reflected in our commitment to fair compensation for a job well done, in line with the SA 8000 social accountability standard. We organise a variety of events that strengthen team spirit and loyalty, support knowledge sharing, promote health awareness, and create a positive working environment. We place special emphasis on training and education, encourage innovative ideas, and actively work to prevent workplace accidents.



LOOKING FORWARD

With 200 years of tradition, the Impol Group is one of Slovenia's oldest companies and among the country's largest exporters. Our management remains firmly focused on a forward-looking strategy, underpinned by long-term plans for sustainable development and growth.



*Extruded
Products*



**Exact
dimensions.
Infinite solutions.**

Precision

Dimensional Limitations of Profiles and Sections

ALLOYS SERIES 1XXX, 3XXX, 6XXX, 7003 AND 7020

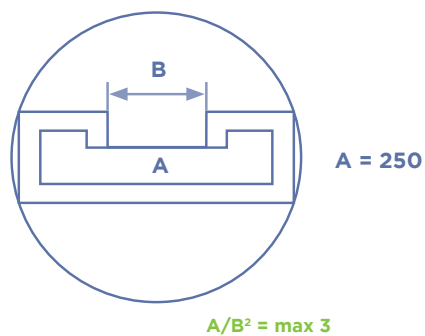
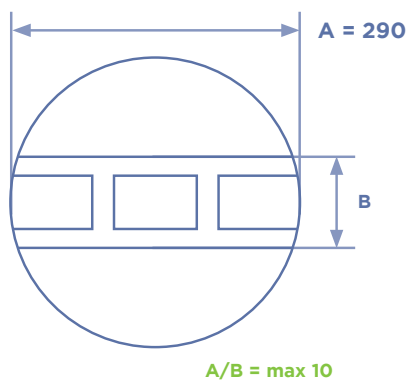
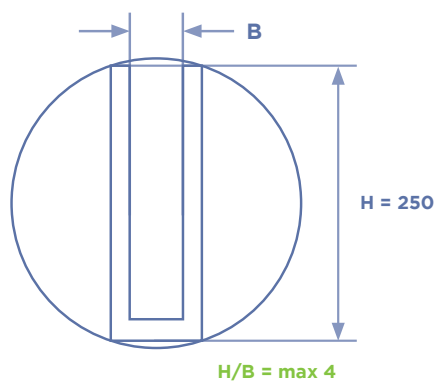
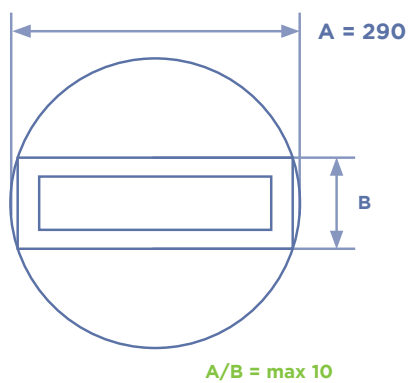
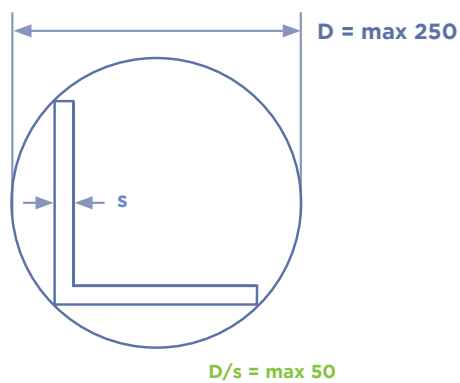
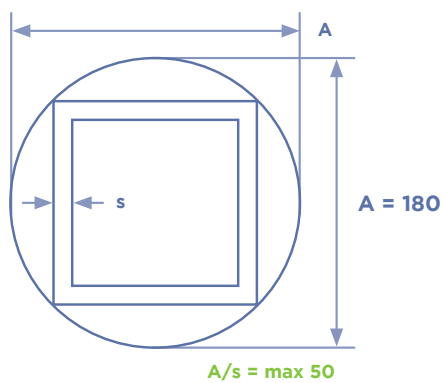
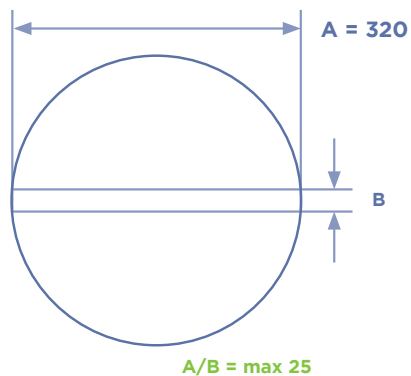
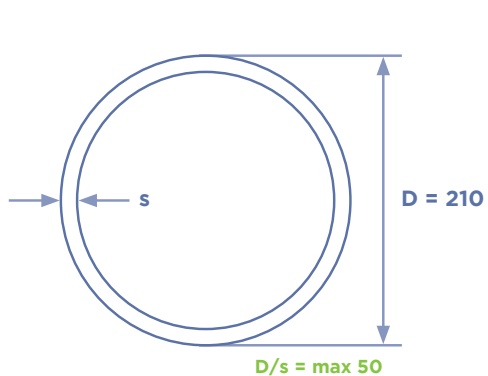

ALSO 40MN DIRECT PRESS: circle D max = 320mm, profile H max = 250mm

ASTM

**1.2
mm**

**Impol
manufactures
sections for the
following uses**

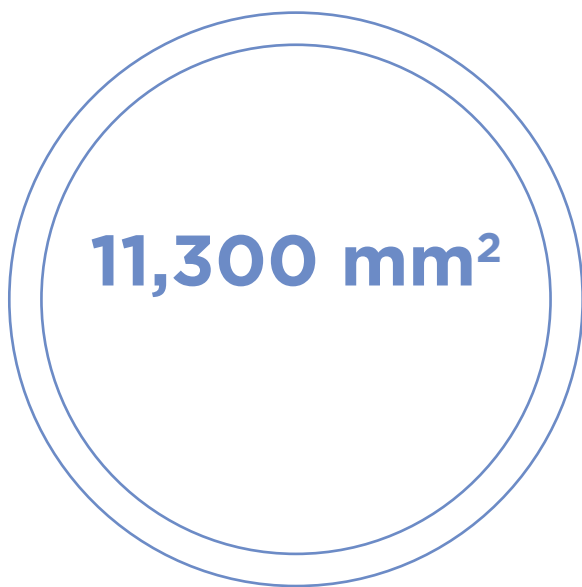

DIN

NF

EN

Mechanical Equipment

Own foundry, with a total capacity of **180,000 tonnes per year** (capacity for the needs of extrusion of over 90,000 tonnes) gives us a lot of advantages on the market. It allows us flexible production and development of new alloys and technologies. However, to fill the capacity on the extrusion press we annually process around **25,000 tonnes of material** from external suppliers. Therefore we produce over **77,000 tonnes of finished extruded products** per year on seven extrusion presses as described below.

SOFT ALLOYS PLANT

		12.5 MN	20 MN	25 MN	28 MN	40 MN
Diameter of input billet	[mm]	152	203	203	228	279
	[inch]	6	8	8	9	11
Optimal sections	[mm ²]	180 - 550	400 - 1500	400 - 2000	700 - 3700	200 - 12000
	[inch]	0,28 - 0,85	0,62-2,33	0,62-3,10	1,08-5,74	0,31-18,60
Optimal length of section	[mm]	800 - 7530	1500 - 12400	1500 - 8000	1500 - 8400	1500 - 8000
	[ft]	2,6 - 24,7	4,9 - 40,7	4,9 - 24,3	4,9 - 27,6	4,9 - 24,3
Alloys		1xxx, 6xxx	1xxx, 6xxx	1xxx, 3xxx, 6xxx, 7003, 7020	1xxx, 3xxx, 6xxx, 7003, 7020	1xxx, 3xxx, 6xxx, 7003, 7020

HARD ALLOYS PLANT

		20 MN	35 MN	55 MN
Diameter of input billet [mm]	[mm]	218	275	282
	[inch]	8,5	11	11
Optimal sections of products [mm ²]	[mm ²]	35 - 3340	300 - 12670	314 - 25000
	[inch]	0,05 - 5,18	0,46 - 19,64	0,49 - 38,75
Optimal length of products [mm]	[mm]	2000 - 6000	2000 - 6000	2000 - 6000
	[ft]	6,5 - 19,7	6,5 - 19,7	6,5 - 19,7
Alloys		1xxx, 6xxx, 2011, 5754, 7003, 7020	1xxx, 2xxx, 3xxx, 4xxx, 5xxx, 6xxx, 7xxx	1xxx, 2xxx, 3xxx, 4xxx, 5xxx, 6xxx, 7xxx

SHORTER LENGTHS OF SECTIONS ARE POSSIBLE BASED ON CUSTOMER'S REQUIREMENTS.

Alloys and tempers according to EN 573 and AA ASTM

EN 573	AA ASTM	EXTRUDED BARS TEMPERS	DRAWN BARS TEMPERS	TUBES TEMPERS	PROFILES
EN AW 1050A		F/H112/H111/O	H14/H18/H111/O		
EN AW 1070A		F/H112/H111/O	H14/H18/H111/O		
EN AW 1350		F/H112/H111/O	H14/H18/H111/O		
EN AW 2011* EN AW 2011 RoHs 2011 LF	AA 2011* AA 2011 RoHS 2011 LF	T6	T3/T8	T3/T8	T6
EN AW 2014 EN AW 2014A	AA 2014	T4/T4510/T4511 T6/T6510/T6511	T4/T6	/	T4/T4510/T4511 T6/T6510/T6511
EN AW 2017A	AA 2017	T4/T4510/T4511	T3	/	T4/T4510/T4511
EN AW 2024	AA 2024	T4/T4510/T4511 T6/T6510/T6511	T3/T351/T8/T851	/	T4/T4510/T4511 T6/T6510/T6511
EN AW 2030 2030 LF		T4	T3	/	T4
EN AW 2618A		T6	T6	/	T6
EN AW 2033		T4/T4510/T4511 T6/T6510/T6511	T3/T8	/	T4/T4510/T4511 T6/T6510/T6511
EN AW 3003		F/H112/H111/O	H14/H18/H111/O	F/H112/H111/O	F/H112/H111/O
EN AW 3103		F/H112/H111/O	H14/H18/H111/O	F/H112/H111/O	F/H112/H111/O
EN AW 4032		T6	T6		T6
EN AW 5051		F/H112/H111/O	H14/H111/O	F/H112	F/H112/H111/O
EN AW 5754	AA 5754	F/H112/H111/O	H14/H18/H111/O	H14/H18/H111/O	F/H112/H111/O
EN AW 5019	AA 5056	F/H112/H111/O	H14/H18/H111/O	/	F/H112/H111/O
EN AW 5083	AA 5083	F/H112/H111/O	H14/H18/H111/O	/	F/H112/H111/O
EN AW 6060		T6/T6510/T6511	T4/T6	T6/T6510/T6511 T4/T6	T6/T6510/T6511
EN AW 6101 EN AW 6101 A EN AW 6101B		T6/T6510/T6511	T4/T6	T6/T6510/T6511 T4/T6	T6/T6510/T6511
EN AW 6063		T6/T6510/T6511	T4/T6/T66	T6/T6510/T6511 T4/T6/T66	T6/T6510/T6511
EN AW 6005 EN AW 6005A EN AW 6005B		T6/T6510/T6511	T4/T6		T6/T6510/T6511

EN AW 6082	AA 6082	T6/T6510/T6511	T4/T6/T651		T6/T6510/T6511
EN AW 6061	AA 6061	T6/T6510/T6511	T4/T6/T651		T6/T6510/T6511
EN AW 6262	AA 6262	T6/T6510/T6511	T6/T8/T9		T6/T6510/T6511
EN AW 6012 6012 Rohs	AA 6012	T6/T6510/T6511	T4/T6		T6/T6510/T6511
EN AW 6064A		T6/T6510/T6511	T6/T8/T9		T6/T6510/T6511
	AA 6020	T6	T8		T6
EN AW 6026 EN AW 6026 LF	AA 6026 AA 6026 LF	T6/T6510/T6511	T6/T8/T9	T6/T6510/T6511 T6/T8/T9	T6/T6510/T6511
EN AW 6182			T6	T6/T6510/T6511 T6	T6/T6510/T6511
AA 6028		T6/T6510/T6511	T6/T651	T6/T6510/T6511 T6/T651	T6/T6510/T6511
EN AW 6023		T6/T6510/T6511	T6/T8	T6/T6510/T6511 T6/T8	T6/T6510/T6511
EN AW 6262A	AA 6262A	T6/T6510/T6511	T6/T8/T9	T6/T6510/T6511 T6/T8/T9	T6/T6510/T6511
	AA 6066	T6/T6510/T6511	T6	T6	T6/T6510/T6511
EN AW 6056		T6/T6510/T6511	T6	T6/T6510/T6511 T6	T6/T6510/T6511
EN AW 6110A		T6/T6510/T6511	T6	T6/T6510/T6511 T6	T6/T6510/T6511
EN AW 7003		T6	T6		T6
EN AW 7020		T6/T6510/T6511	T6		T6/T6510/T6511
EN AW 7022		T6/T6510/T6511	T6	/	T6/T6510/T6511
En AW 7075	AA 7075	T6/T6510/T6511/ T73	T6/T651	/	T6/T6510/T6511
EN AW 7175		T6/T6510/T6511	T6/T651	/	T6/T6510/T6511
EN AW 7010		T6	T6	/	T6
EN AW 7050		T6	T6	/	T6
EN AW 7150		T6	T6	/	T6
EN AW 7049A		T6	T6	/	T6

Alloys and tempers according to AMS and BS standards



ALLOY		TEMPER	
AA 2011*	AMS QQ-A 225/3A	drawn	T3/T8
AA 2014	AMS 4121	drawn	T651
AA 2014	AMS 4153	extruded	T6
AA 2017	AMS 4118	drawn	T4
AA 2017	AMS 4118	drawn	T451
AA 2024	AMS 4120	drawn	T4
AA 2024	AMS 4120	drawn	T351
AA 2024	AMS 4339	drawn	T851
AA 2024	AMS 4165	extruded	T3510/T3511/T8510/T8511
AA 2024	AMS 4152	extruded	T3
AA 6061	AMS 4117 CLASS 2*	drawn	T651/T6
	AMS 4117 CLASS 1*	drawn	T6
AA 6061	AMS 4150 CLASS 1* OR CLASS 2*	extruded	T6
AA 6061	AMS 4173 CLASS 1* OR CLASS 2*	extruded	T6510/T6511
AA 7075	AMS 4122	drawn	T6
AA 7075	AMS 4123	drawn	T651/t6
AA 7075	AMS 4154	extruded	T6/T6510/T6511
AA 4032	AMS 4319	drawn	T651
EN AW 6082	L111 + BS 5L100 1&5	extruded	T6510/T6511
EN AW 2014A	L168 + BS 5L100 1& 5	extruded	T6511

AA 2011* OPTION ALSO IN LEAD FREE ALLOY 2011 LF ACCORDING IMPOL NORM

CLASS 1 - FURNACE SOLUTION HEAT TREATED IN ACCORDANCE WITH AMS2772 AND PRECIPITATION HEAT TREATED IN ACCORDANCE WITH AMS2772.

CLASS 2 - EXTRUDED AND PRESS SOLUTION HEAT TREATED IN ACCORDANCE WITH ASTM B807/B807M AND PRECIPITATION HEAT TREATED IN ACCORDANCE WITH AMS2772.

FREE-CUTTING ALLOYS

ROHS 1	ROHS 2	ROHS 3	
2002/95/EC From July 2006	2011/65/EU From January 2013	2018/740/EU From June 2021	
Max. 0.60 % Pb	Max. 0.40 % Pb	Max. 0.10 % Pb	
			
EN AW 2011	EN AW 2011 RoHS AA 2011 RoHS	2011 LF	with Bi
		AA 2041	
EN AW 6262	EN AW 6026	EN AW 6026 LF AA 6026 LF	with Bi
	EN AW 6064A	EN AW 6262 A	with Sn and Bi
EN AW 6012	EN AW 6012R	EN AW 6023	with Sn and Bi
		AA 6028	with Sn and Bi
EN AW 2007*	AA 2028 A	2030 LF	with Bi
EN AW 2030*		AA 2044	with Sn and Bi
		EN AW 2033	

- ELV conform
- Pb max. 1.00 %

BARS FOR FORGING

2xxx	EN AW-2014	EN AW-2014A	EN AW-2017A	EN AW-2024	EN AW-2618A
	EN AW-2011				
6xxx	EN AW-6082	EN AW-6110A	EN AW-6061	EN AW-6056	EN AW-6082mod.
	AA 6111				
7xxx	EN AW-7010	EN AW-7020	EN AW-7050	EN AW-7150	EN AW-7075
	AA 7055	EN AW-7049A	EN AW-7175		
Other	EN AW-4032	EN AW-5754			

*Cast bars for forging in alloys EN AW 6082 and EN AW 6110A

Available Dimensions of Products

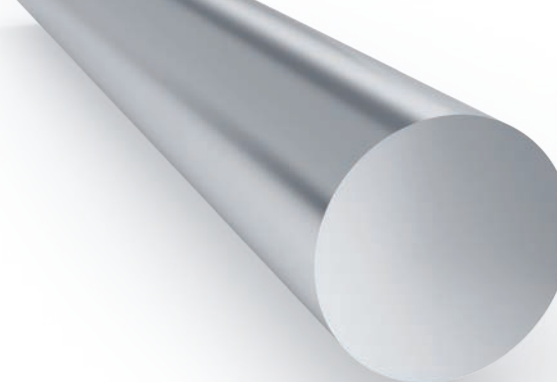

EXTRUDED BARS

SHAPE		DIMENSION 1XXX AND 6XXX ALLOYS	DIMENSION OTHER ALLOYS
ROUND		6 - 180mm 0,236' - 7,09'	20-180 mm 0,787' - 7,09'
SQUARE		8-140 mm 0,315' - 5,51'	20-140 mm 0,787' - 5,51'
HEXAGONAL		8-120 mm 0,315' - 4,73'	20-120 mm 0,787' - 4,73'
FLAT		H: 2,0 - 100 mm W: 10,0 - 300 mm H: 0,08' - 3,94' W: 0,39' - 11,81'	H: 10,0 - 100 mm W: 20,0 - 140 mm H: 0,39' - 3,94' W: 0,787' - 5,51'

*Standard length 2-6m or in agreement with customer.

DRAWN BARS

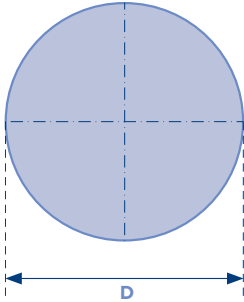
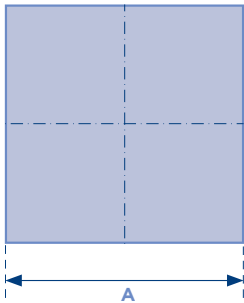
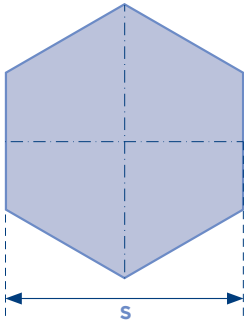
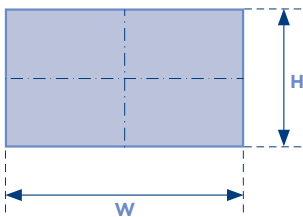
SHAPE	DIMENSION 2011 AND 6XXX ALLOYS	DIMENSION OTHER ALLOYS
ROUND 	2,515 - 76,2 mm 0,099' - 3,0'	2,515 - 76,2 mm 0,099' - 3,0'
SQUARE 	5,0 - 63,5 mm 0,197' - 2,5'	7 - 63,5 mm 0,275' - 2,5'
HEXAGONAL 	5,0 - 63,5 mm 0,197' - 2,5'	7 - 63,5 mm 0,275' - 2,5'
FLAT 	H: 10,0 - 50 mm W: 12,7 - 76,2 mm H: 0,39' - 1,97' W: 0,50' - 3,0'	H: 10,0 - 50 mm W: 12,7 - 76,2 mm H: 0,39' - 1,97' W: 0,50' - 3,0'

*Standard length 2-4,5m or in agreement with customer.

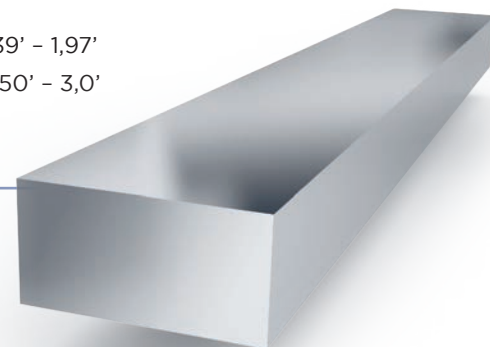

Available Dimensions of Products

TUBES

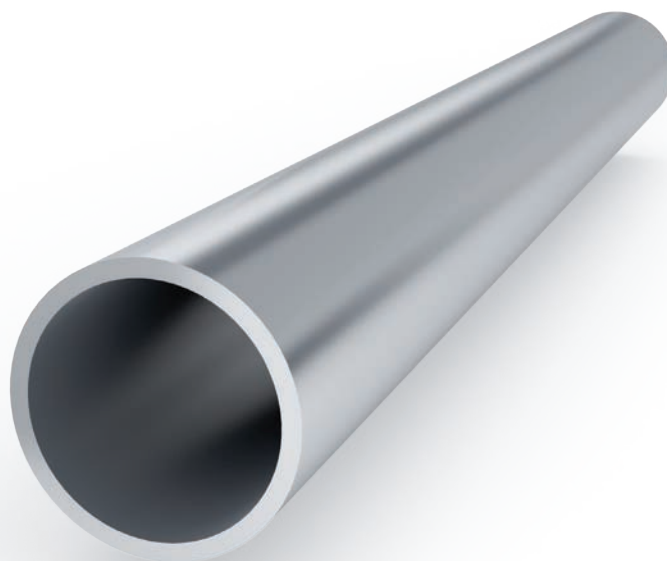
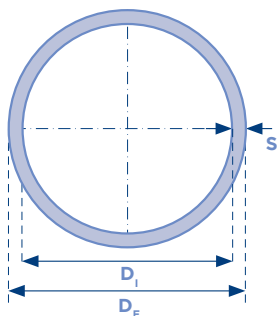

TUBES	7003, 7020 AND 6XXX ALLOYS		5754, 2011	
SEAMLESS	de = 25 - 95mm	(0,984'-3,74')	de = 25 - 95mm	(0,984'-3,74')
	di = 16 - 74mm	(0,630'-2,91')	di = 16 - 74mm	(0,630'-2,91')
	s = 2,5 - 25mm	(0,098'-0,984')	s = 2,5 - 25mm	(0,098'-0,984')
CHAMBER EXTRUDED	de = 10 - 210mm	(0,394'-8,268')		
	s = 1,5 - 25mm	(0,059'-0,984')		
DRAWN TUBES	de = 25 - 76,2mm	(0,984'-3,0')	de = 25 - 95mm	(0,984'-3,74')
	di = 16 - 74mm	(0,630'-2,91')	di = 16 - 74mm	(0,630'-2,91')
	s = 2,5 - 25mm	(0,098'-0,984')	s = 2,5 - 25mm	(0,098'-0,984')

FERRULES - OVAL TUBES

IN ACCORDANCE WITH DIN 3093 STANDARD, FROM NO. 16 TO 32.

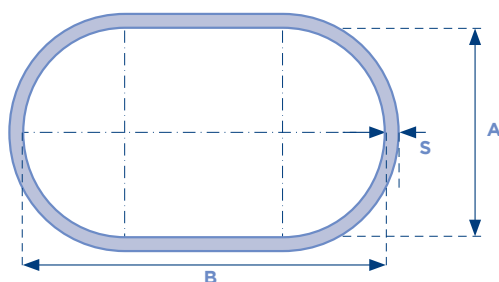

Profiles for Automotive use

OEM - SPECIFICATION	REMARK
DAIMLER DBL 1172.10	Crash
DAIMLER DBL 1172.20	Non-Crash
DAIMLER DBL 1172.30	Crash
DAIMLER DBL 1172.40	Crash
DAIMLER DBL 1172.50	Crash
VW TL 116-C20	Crash
VW TL 116-N20	Non-Crash
VW TL 116-C24	Crash
VW TL 116-N24	Non-Crash
VW TL 116-C28	Crash
VW TL 116-N28	Non-Crash
BMW ALMGSI-CHA-T1	Non-Crash
BMW ALMGSI-CHA	Non-Crash
BMW ALMGSI-STD-T1	Non-Crash
BMW ALMGSI-STD	Non-Crash
BMW ALMGSI-CRA-T1	Crash
BMW ALMGSI-CRA	Crash
BMW ALMGSI-HST-T1	Crash
BMW ALMGSI-HST	Crash



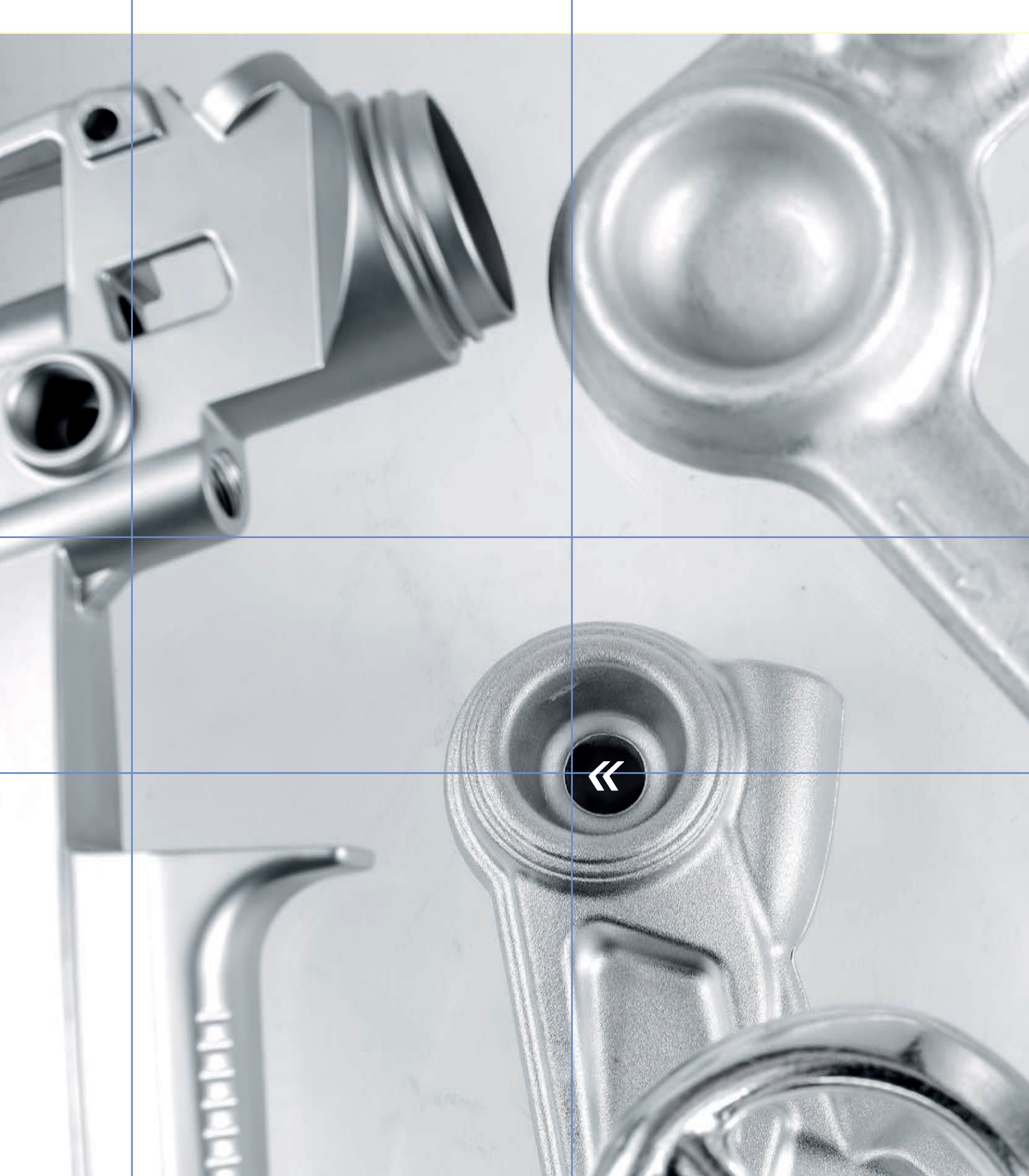

Blanks



FORCE RANGE

0.45-1.8 MN

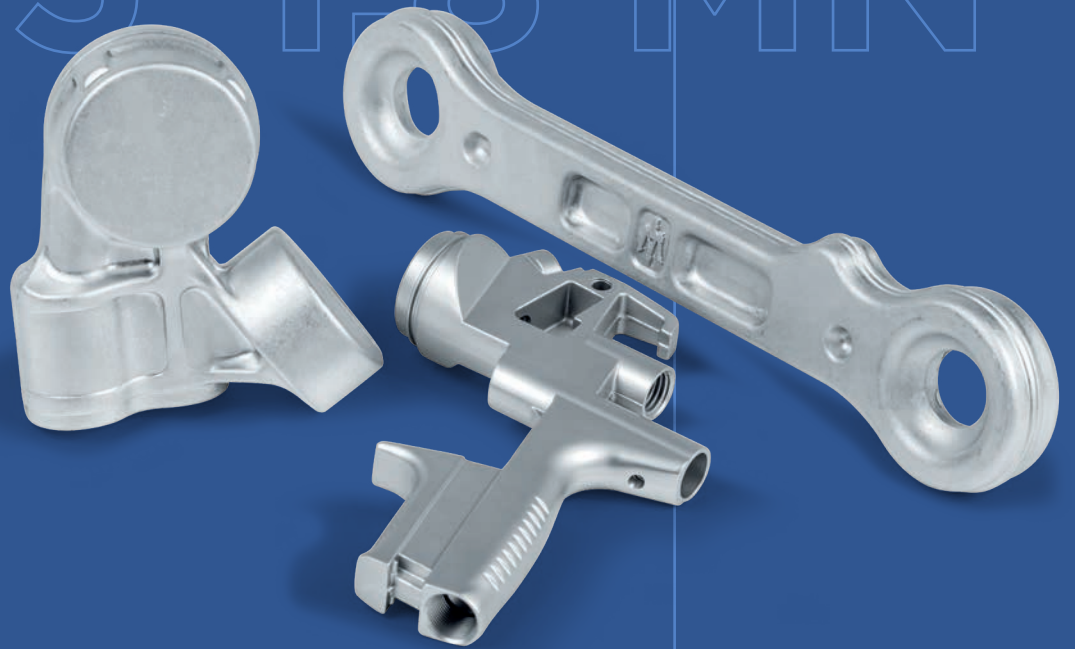

5 million
forgings

flexibility

A young company with old experience

Our activity is hot forging, which has long been used on an industrial scale for forging aluminium alloys.

We have a wide range of forgings available, including those considered D-parts. This label signifies products that are essential for safety and, therefore, must be documented accordingly. Our forgings stand out in their dimensional accuracy and their excellent mechanical properties.

All processes are thoroughly planned, executed and monitored. Statistical methods are applied for production control.

We produce approx. 3 million different forgings per year. For tooling, we collaborate with toolmakers, who not only make sure the delivery periods are kept short, but also ensure excellent quality to enhance our flexibility, which itself is of primary importance for success on the market.

A WIDE RANGE OF ALUMINIUM ALLOYS

FROM 2xxx TO 7xxx

Process

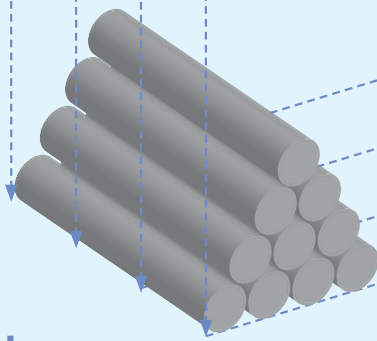

bars

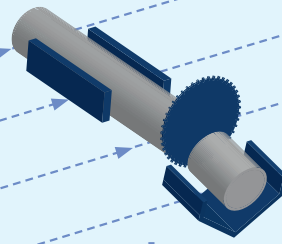

cut

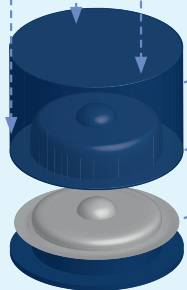

trimming

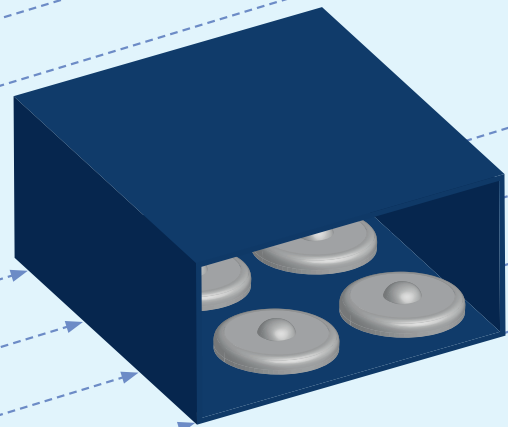

heat treatment

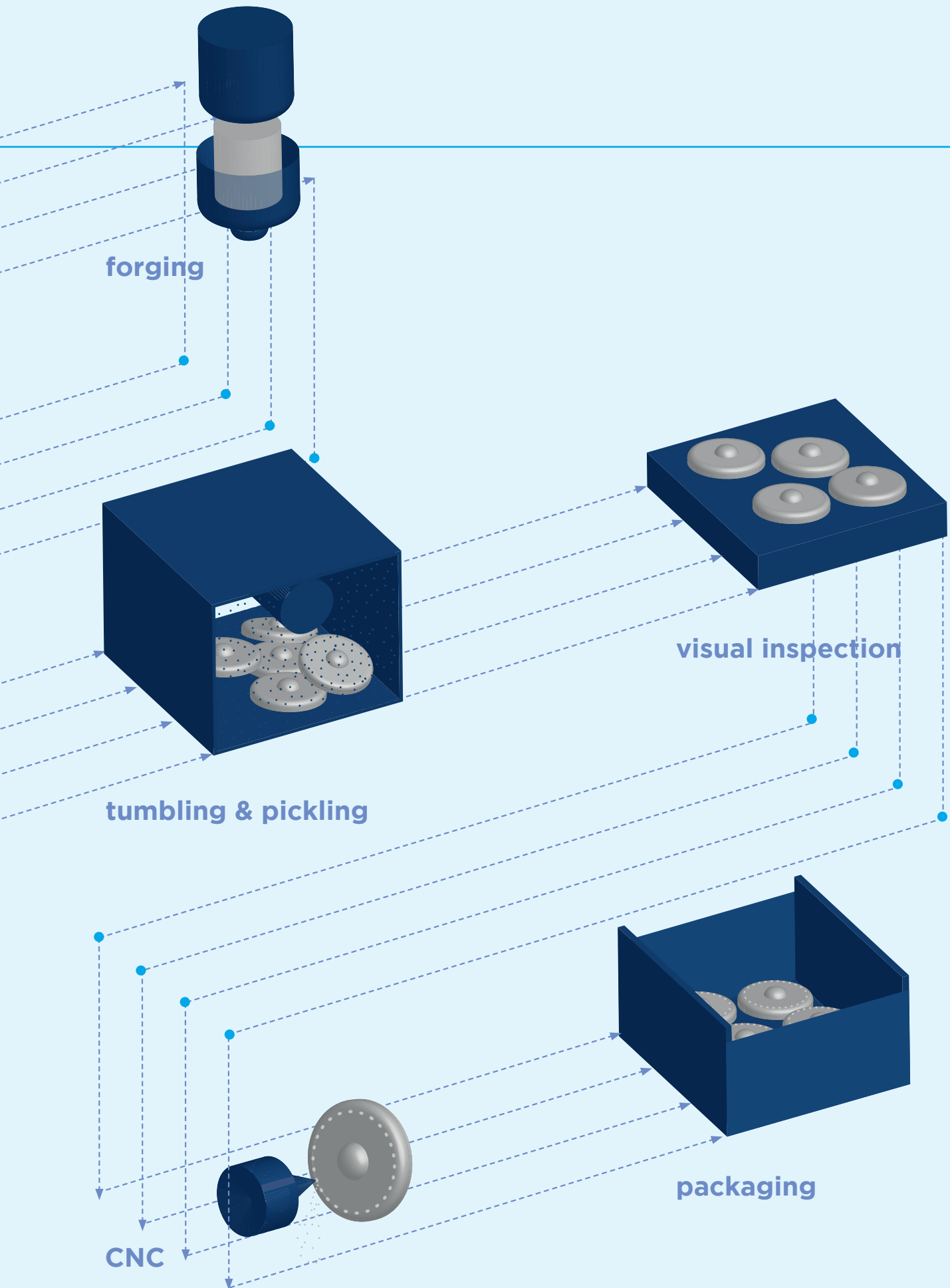

ISO 9001:20

BVQI SINCE 2011

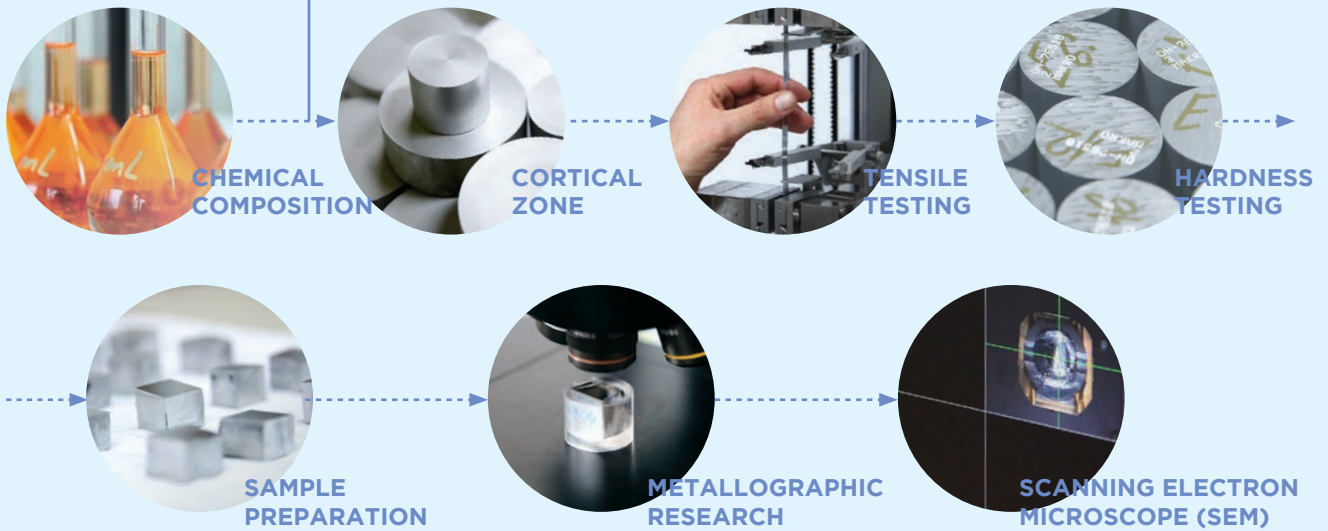

ALLOYS	NORMS	TENSILE PROPERTIES				
		ASTM	RM [N/MM ²]	RP 0.2 [N/MM ²]	A 5 [%]	HB
P AL CU 2.6 MG	2117		320	260	8	100
P AL CU 4.4 MN MG	2014		450	385	5	125
P AL CU 4.4 MG MN	2024		395	260	9	100
P AL CU 5.5 PB BI	2011		335	225	12	90
P AL MG 0.5 SI 0.4 FE	6060		185	135	9	55
P AL MG I SI CU CR	6061		265	240	8	85
P AL SI I MG MN	6082		310	260	6	90
P AL ZN 4.5 MG	7020		345	265	8	100
P AL ZN 5.8 MG CU CR	7075		510	435	6	140
P AL ZN 6 MG 2 CU I ZR	7012		510	470	7	150
P AL ZN 5.8 MG 0.8 ZR	7003		320	210	10	90

Uncompromised Quality

15

The quality of our products is subject to certification and testing in the state-of-the-art independent labs of the Impol Group, i.e. the labs for metallurgical, metallographic and chemical testing.

THE METALLURGICAL TESTING LAB

It conducts mechanical tests, hardness tests and tests of the material's hard-drawing properties. Keeping up with the latest findings in the field of testing, we are consistent in implementing the most recent standards in our testing methods.

The metallographic testing lab is concerned with analysing the material's history and characterising the segments of its microstructure. Metallographic analysis is conducted via optical microscopy. Electron microscopy featuring an EDS detector is used to produce more reliable results in terms of identifying the type of material and individual fragments.

THE CHEMICAL TESTING LAB

It carries out spectroscopic analyses of the chemical composition of aluminium alloys, analytical chemistry and waste water analysis.

CERTIFIED QUALITY

We are an ISO 9001:2015 certified company. Quality is our main priority and a central feature of our corporate philosophy. We always make sure we exceed customer expectation on the quality front. Our vision is to achieve optimal quality for the appropriate price on the marketplace.



extreme
demand

EXTREME MECHANICAL PROPERTIES

The rapidly growing trend of aluminium blanks in the automotive sectors is also reflected in our company. Each year we increase the number of components produced for new cars.

We collaborate with producers of low volume luxury cars with extreme demands. Normally we manufacture safety components for engine, suspension, transmission and brake systems. Higher mechanical properties than standard were developed in order to meet the requirements.

luxury cars

LOYAL CUSTOMERS/PARTNERS



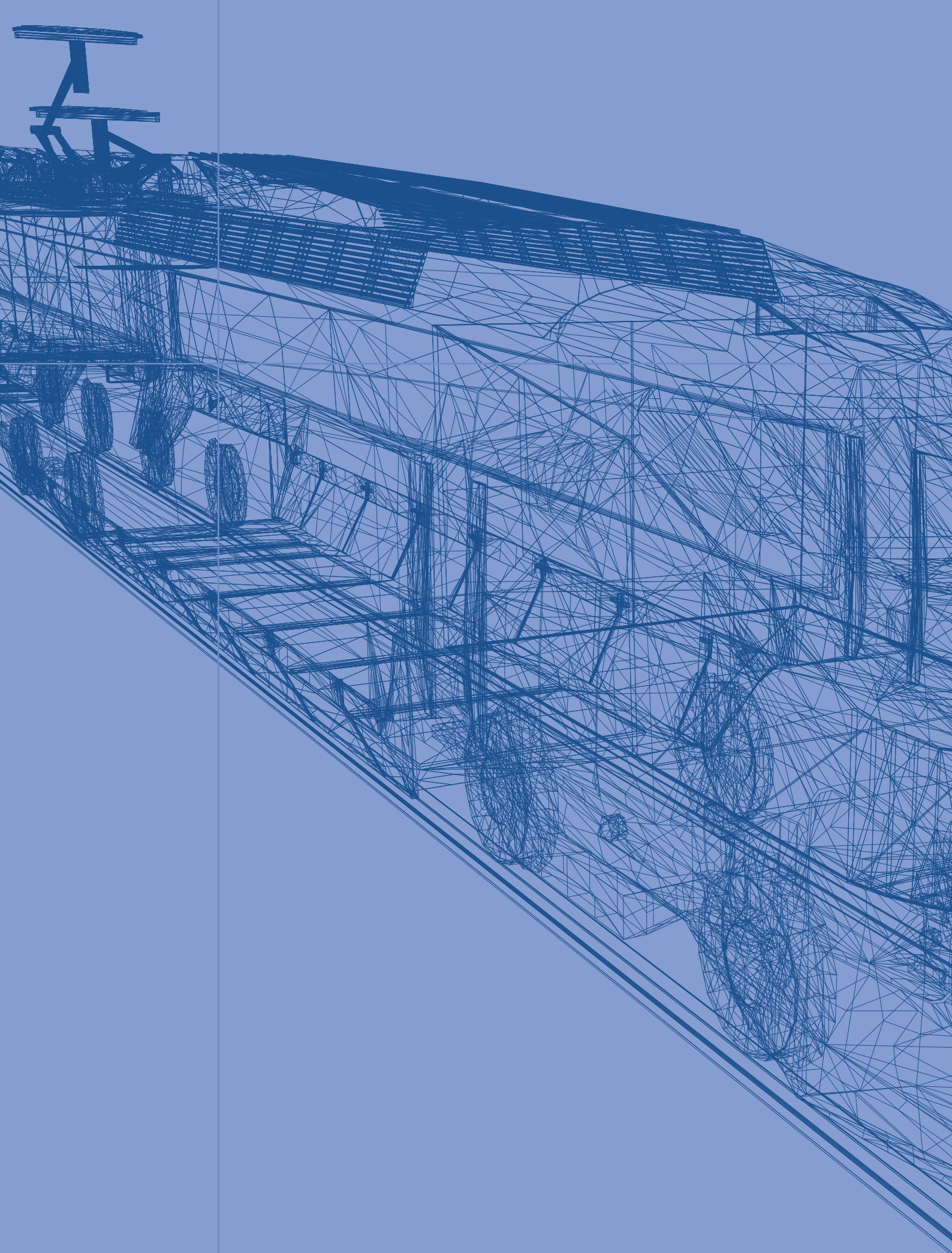

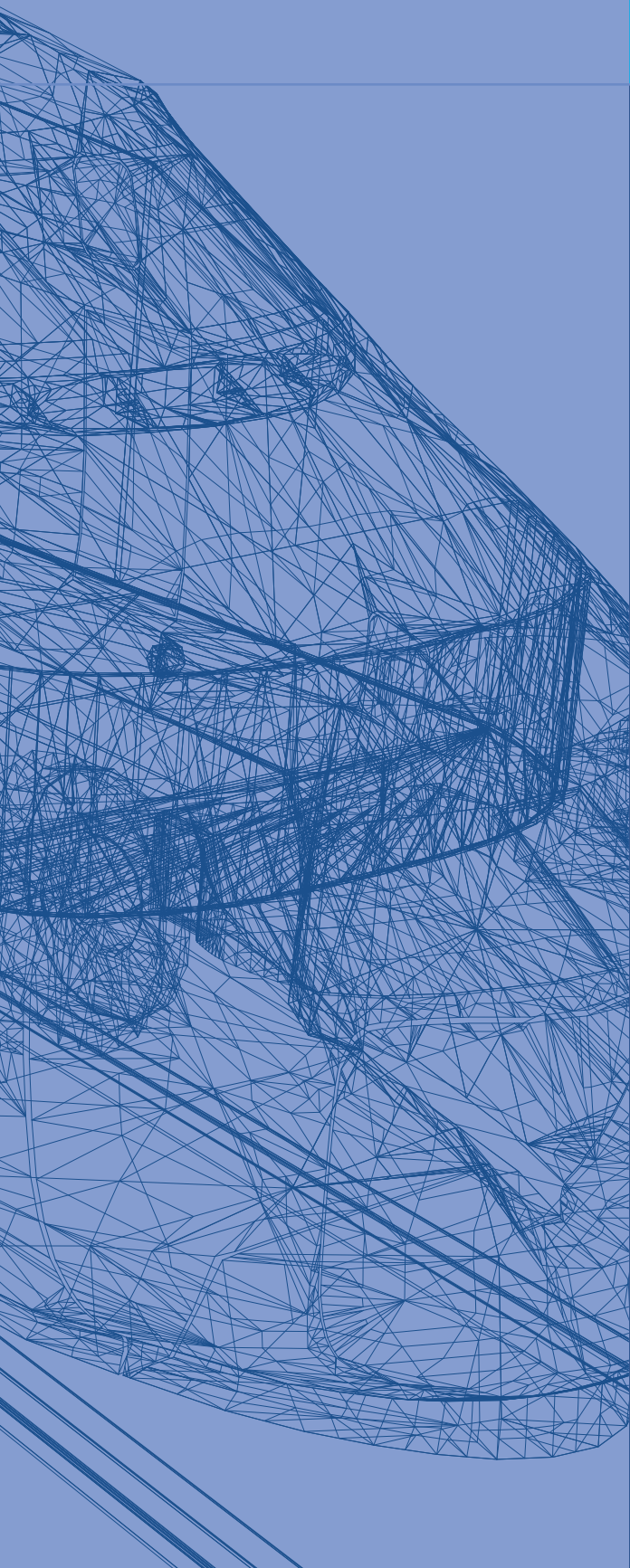

*Parts
for the
compressor
industry*



A VERY IMPORTANT SECTOR

A significant percentage of our production is dedicated to the compressor industry, mainly compressors for various refrigeration applications. The main products are connection rods and valve housings.

refrigeration applications

LOYAL CUSTOMERS/PARTNERS







Parts for bicycles



crank pedals

FATIGUE

On bicycles, aluminium forging technology has been used for several decades. Aluminium components are used because they guarantee a good compromise between high mechanical properties and weight. From the commercial point of view, they are more economical compared to composite material, like carbon for example. Our most important product in this branch is our crank pedal.

brakes

LOYAL CUSTOMERS/PARTNERS

Campagnolo

MICHE

(F) FORMULA



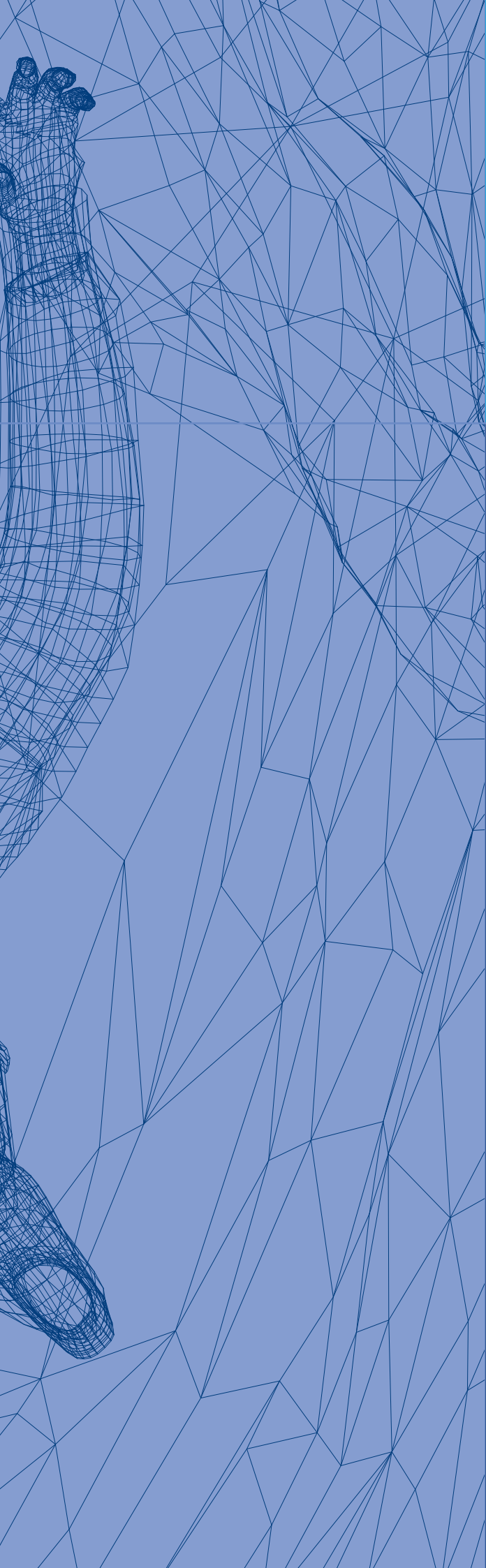

*Other
Forged
parts*

sport

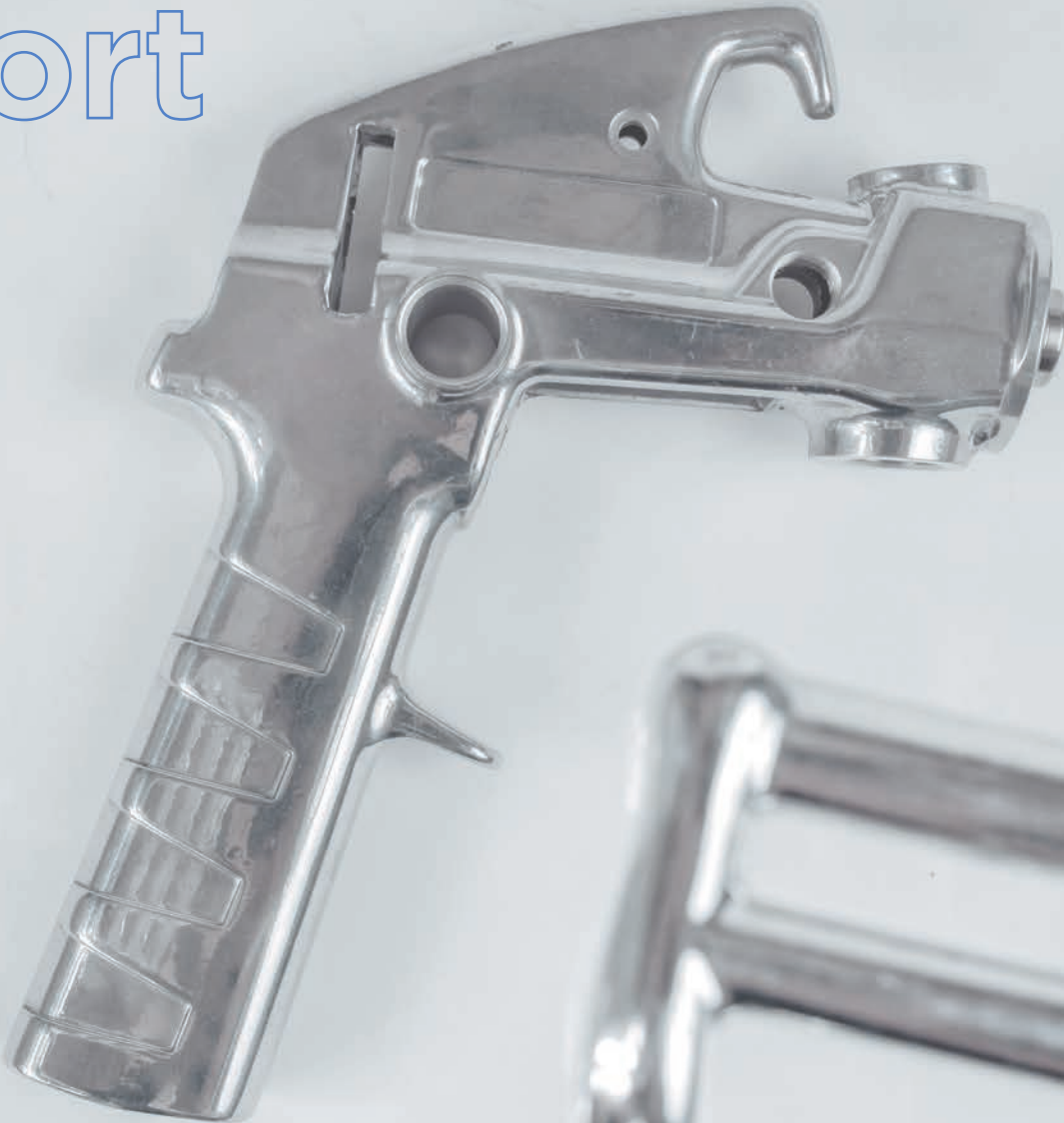

OTHER BRANCHES

A significant percentage of our market covers other branches. It is necessary to emphasise the sports sector (climbing), the armament sector and the sector of spray guns. They are specific from different points of view and are therefore very demanding and tricky. A lot of flexibility with the shortest possible developing time is expected.

painting

LOYAL CUSTOMERS/PARTNERS







*200 years of
excellence, united
with sustainability
and innovation —
Impol continues
to move the world
forward.*





Partizanska 38
2310 Slovenska Bistrica, Slovenia

T: +386 2 845 3100

info@impol.si
www.impol.com